

2015-03 L-Band Upconverter

The 2015-03 L-band Upconverter converts 70 ± 18 MHz to 950 to 1525 MHz in 1 MHz steps with low group delay and flat frequency response. Synthesized local oscillators (LO) provide frequency selection. Multi-function push button switches select the RF frequency, gain, and other parameters. Front panel LEDs provide indication of DC power (green), PLL alarm (red), remote operation (yellow) or the TX carrier is muted (yellow). Variable attenuators for the IF input and output provide a gain range of -10 to +30 dB as adjusted by the front panel multi-function push-button switches. Remote operation allows selection of frequency and gain. Parameter selection and frequency and gain settings appear on the LCD display. Connectors are BNC female for IF and the optional external reference input and output, and Type F female for the RF output. SSPB +24 VDC, 2.5 Amps and 10 MHz reference can be inserted on the RF line as added options. The 10 MHz option includes a 10 MHz output connector which contains either the internal or external 10 MHz reference signal. A high stability (±0.01ppm) option is also available. The unit is powered by a 100-240 ± 10% VAC power supply, and housed in a 1 3/4" X 19" X 16" rack mount chassis.

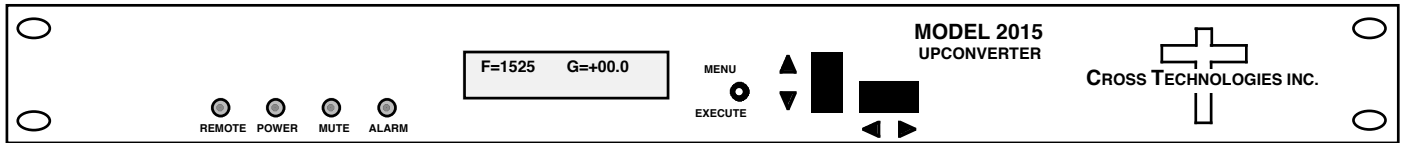

2015-03 Upconverter, Front Panel

EQUIPMENT SPECIFICATIONS*

Input Characteristics (IF)

Impedance/Return Loss 75 Ω /18 dB
 Frequency 70 ± 18 MHz
 Input Level -40 to -10 dBm

Output Characteristics (RF)

Impedance/Return Loss 75 Ω/12 dB
 Frequency 950 to 1525 MHz
 Output level 0 to -20 dBm
 Output 1 dB comp. +5 dBm

Channel Characteristics

Gain range (adjustable) -10.0 to +30.0 dB
 Frequency Response ±1.5 dB, 950 - 1525 MHz ; ± 0.5 dB, 36 MHz BW
 Spurious Response < -50 dBc, in band
 Group Delay, max 0.01 ns/MHz² parabolic; 0.03 ns/MHz linear; 1 ns ripple
 Frequency Sense Non-inverting

Synthesizer Characteristics

Frequency Accuracy ± 1.0 ppm max over temp (±0.01 ppm, option-H)
 Frequency Step 1.0 MHz (as low as 1 kHz steps available)

Phase Noise @ Freq	100Hz	1kHz	10kHz	100kHz	1MHz
dBc/Hz	-75	-75	-85	-100	-120

10 MHz Level (In or Out) 3 dBm, ± 3 dB, 75 ohms (option-E)

Controls, Indicators

Frequency Selection direct readout LCD; manual or remote selection
 Gain Selection direct readout LCD; manual or remote selection
 Pwr; Alarm; Rem; Mute Green LED; Red LED; Yellow LED; Yellow LED
 Remote RS232C, 9600 baud (RS485, option-Q)
 (Ethernet Interface, option-W8)

Other

RF Connector Type F (female)
 IF Connectors BNC (female)
 10 MHz Conn. (In & Out) BNC (female) (option-E)
 Alarm/Remote Connector DB9 (female) - NO or NC contact closure on Alarm
 Size 19 inch, 1RU standard chassis 1.75" high X 16.0" deep
 Power 100-240 ±10% VAC, 47-63 Hz, 45 watts max

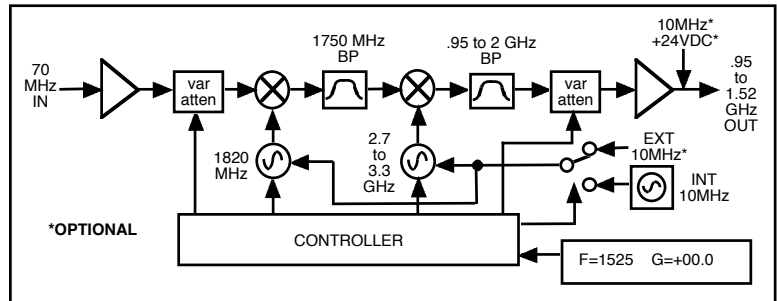

Available Options

- E – External 10 MHz ref input & output w/RF insertion
- H – High Stability (±0.01ppm) internal reference
- V – SSPB Voltage, +24VDC, 2.5 amps
- Q – RS485 Remote Interface
- T – Temperature Sensor
- W8 - Ethernet M&C Remote Interface
- Z – Attenuator 0.1 dB on Upconverter
- X or X1 - 125 or 100 KHz steps**

Connectors/Impedance

- B – 75Ω BNC (RF), 75Ω BNC (IF)
- C – 50Ω BNC (RF), 75Ω BNC (IF)
- D – 50Ω BNC (RF), 50Ω BNC (IF)
- N – 50Ω N-type (RF), 75Ω BNC (IF)
- M – 50Ω N-type (RF), 50Ω BNC (IF)

*10°C to 40°C; Specifications subject to change without notice