

## FEATURES

- ▶ Based on Next Generation SSPA Technology
- ▶ Instant On - No Warm Up Time
- ▶ Lower Power Consumption in a Redundant Configuration
- ▶ Field-Proven Reliability, Lower Lifecycle Costs
- ▶ Integrated BUC
- ▶ 1:1 Redundancy Kits Available



# C-Band PowerStream 757C-o

## The Wavestream Advantage:

- Higher output power with less energy usage.
- Compact product footprint to meet critical space and weight limitations.
- Proven reliability and efficiency.
- Reduced lifecycle maintenance costs.

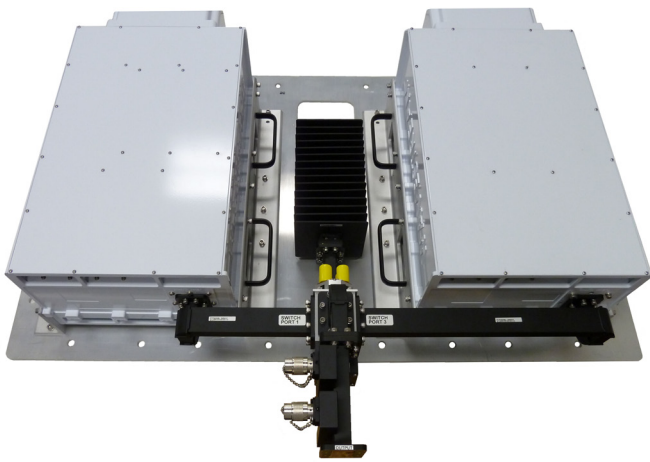

1:1 Redundant Configuration

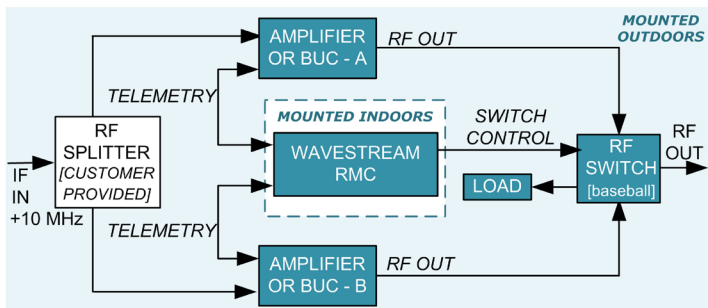

Wavestream's outdoor PowerStream® 757C-o Solid State Power Amplifier (SSPA) provides similar linear operating power as unlinearized 750W Traveling Wave Tube Amplifiers (TWTAs) to support broadcast satellite communications systems worldwide. Based on the same next generation Spatial Power Advantage™ technology as Wavestream's indoor rack-mount SSPAs, the outdoor PowerStream 757C-o amplifier is easy to maintain, and is designed and production-tested to withstand harsh environments. The PowerStream 757C-o can be mounted close to the antenna to significantly reduce waveguide loss. Once installed, the outdoor amplifier is easily controlled from a redundancy controller or a system computer, providing convenient access to power, temperature and status information.

The PowerStream 757C-o incorporates Wavestream's proven, next generation Spatial Power Advantage technology to provide high output power and lower power draw. For system integrators looking to implement new technology while lowering operating costs, the PowerStream 757C-o in a redundant configuration offers lower power consumption to significantly reduce energy costs over the lifecycle of the system.

Optional 1:1 Redundancy Kits are available to provide an integrated solution for uninterrupted, reliable broadcast satellite transmissions. The 1:1 Redundancy Kit integrates the waveguide, switch and mounting hardware, and offers ease of installation and subsequent maintenance to accommodate outdoor mounts.

## RF Specifications

<b>Transmit Frequency</b>	5.85 - 6.425 GHz
<b>IF Frequency</b>	950 - 1525 MHz
<b>Frequency Reference</b> (10 MHz on IF)	0 dB $\pm$ 5 dB
<b>Small Signal Gain</b>	75 dB minimum
<b>Gain Adjustment</b>	20 dB, 0.25 dB steps nominal
<b>Gain Variation</b> (over frequency at fixed temperature)	1.0 dB over 36 MHz 4.0 dB over full band
<b>Gain Variation</b> (over temperature at fixed frequency)	2 dB p-p over operating range
<b>Saturated Output Power</b>	+57.8 dBm nominal
<b>P<sub>1</sub> dB Output Power</b>	> +56.8 dBm
<b>Rated Output Power</b>	+56.8 dBm
<b>Intermodulation *</b> (reference to single carrier level at +54 dBm total output power)	-25 dBc
<b>Spectral Regrowth</b> (For QPSK at 1.5x and OQPSK at 1.0x symbol rate offset at +54 dBm total Output Power)	-30 dBc
<b>Phase Noise</b>	IESS-308/309 - 2 dB
<b>AM/PM Conversion</b> (at +54 dBm)	2.5 deg/dB maximum
<b>Noise Power Density - Transmit</b>	-70 dBW/4 kHz
<b>Noise Power Density - Receive</b>	-150 dBW/4 kHz
<b>Output Spurious</b>	-60 dBc

## Power

<b>AC Power</b>	180-264 VAC, 50-60 Hz
<b>AC Power Draw</b> (typical) (at Rated Output Power)	3.2 kVA maximum
<b>AC Power Draw</b> (at 3 dB Back-off from Rated Output Power)	2.4 kVA
<b>Power Factor</b>	0.99 Typical (0.95 minimum)

\* Guaranteed over temperature and frequency

## Interfaces

IF Input Connector	Type N Female
IF Input Impedance	50 ohms
IF Input VSWR	1.3:1 maximum
RF Output Connector	CPR-137G Waveguide Flange
RF Output VSWR	1.25:1 maximum
RF Sample Port Connector	Type N Female
RF Sample Port	-40 dBc typical
AC Connector	4-Pin Male, Amphenol C016 20C003 100 12
Monitor & Control Connector	19-Pin Male, MS3112E14-19P
Monitor & Control	Serial RS-485 (SA-bus), Serial Control, Ethernet with SNMP Support

## Physical

Size	24.5"L x 12.8"W x 8.5"H
Weight	83 lbs
Operating Temperature (Ambient Air)	-40°C to +60°C
Relative Humidity	100% Condensing
Shock & Vibration	Designed to withstand 20G at 11 ms ½ sine wave non-operating conditions, and MIL-STD-810E, method 514-4 transportation vibration
Altitude	10,000 ft above sea level (operating)

## Options

**1:1 Redundancy Kit** - to include waveguide, switch, cable connectors and mounting hardware

**Rack Mount Controller** - 1U rack-mount chassis to control any Wavestream amplifier in a 1:1 configuration with LCD display and key status LEDs

**Indoor to outdoor cable assemblies** - available in 25', 50', or 100' lengths

## Base Model Number

POB-CSA600



545 West Terrace Drive  
 San Dimas, CA 91773  
 Toll Free: (877) 214-6294  
 sales@wavestream.com  
 www.wavestream.com